

CNC SWISS-TURN

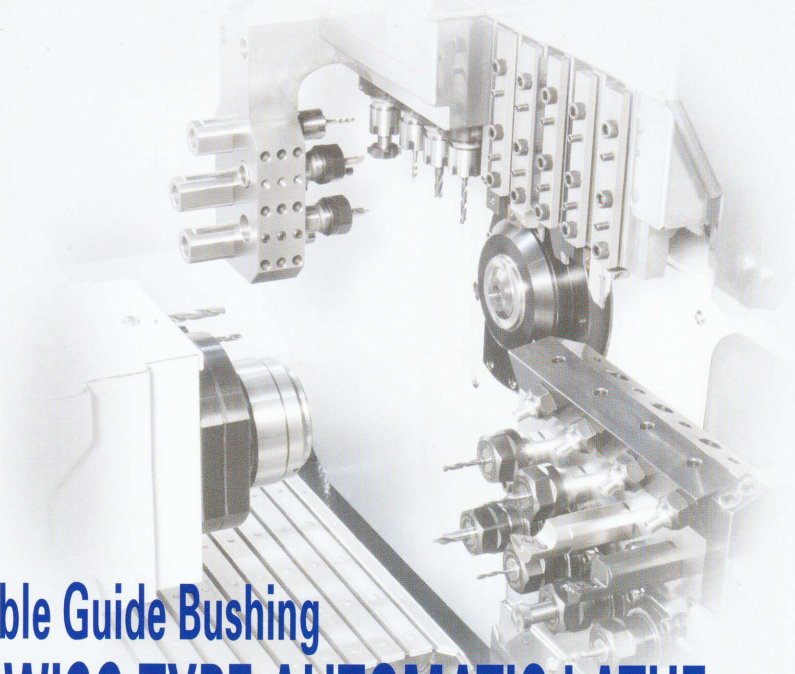

Removable Guide Bushing
CNC SWISS TYPE AUTOMATIC LATHE

SA 20P/26P/32P/38P



NEXTURN
SWISS TURN LEADER

Powerful Cutting, Precise Machining with Removable

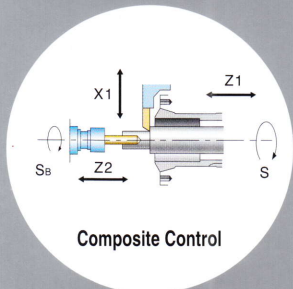

Composite Control

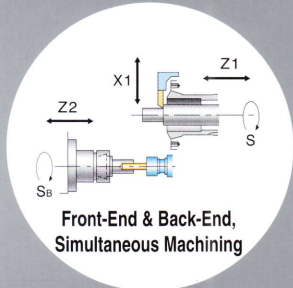

Front-End & Back-End, Simultaneous Machining

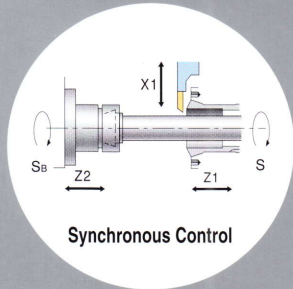

Synchronous Control

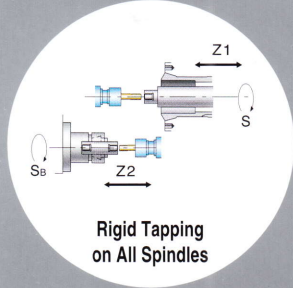

Rigid Tapping on All Spindles

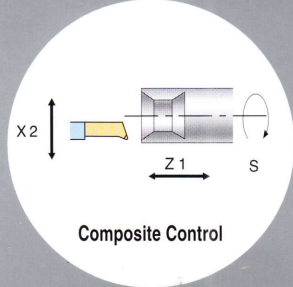

Composite Control

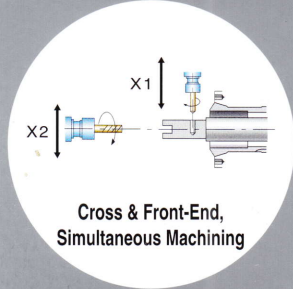

Cross & Front-End, Simultaneous Machining

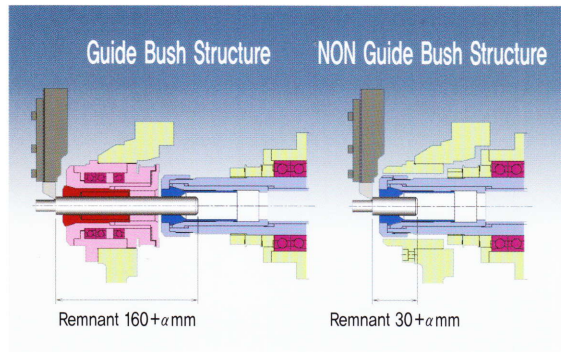

Exchangable Guide Bush, Non Guide Bush System

- Maximise Machining depends on Work Length, due to Exchangable Guide Bush and Non Guide Bush System
- Guide Buh Type allows precision machining, Suitable for Long Part Production
- Non Guide Bush Type allows to use cheaper Drawing Bar, Minimise Bar Remnant for More Economical Production

Powerful Composite Tooling System at High Speed

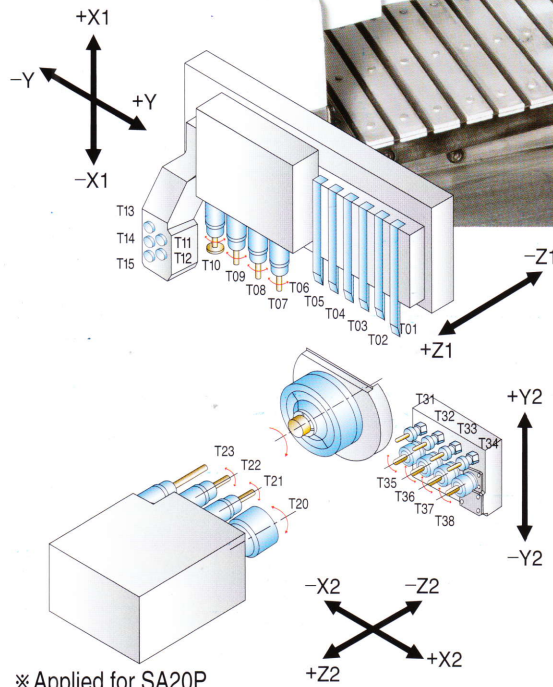
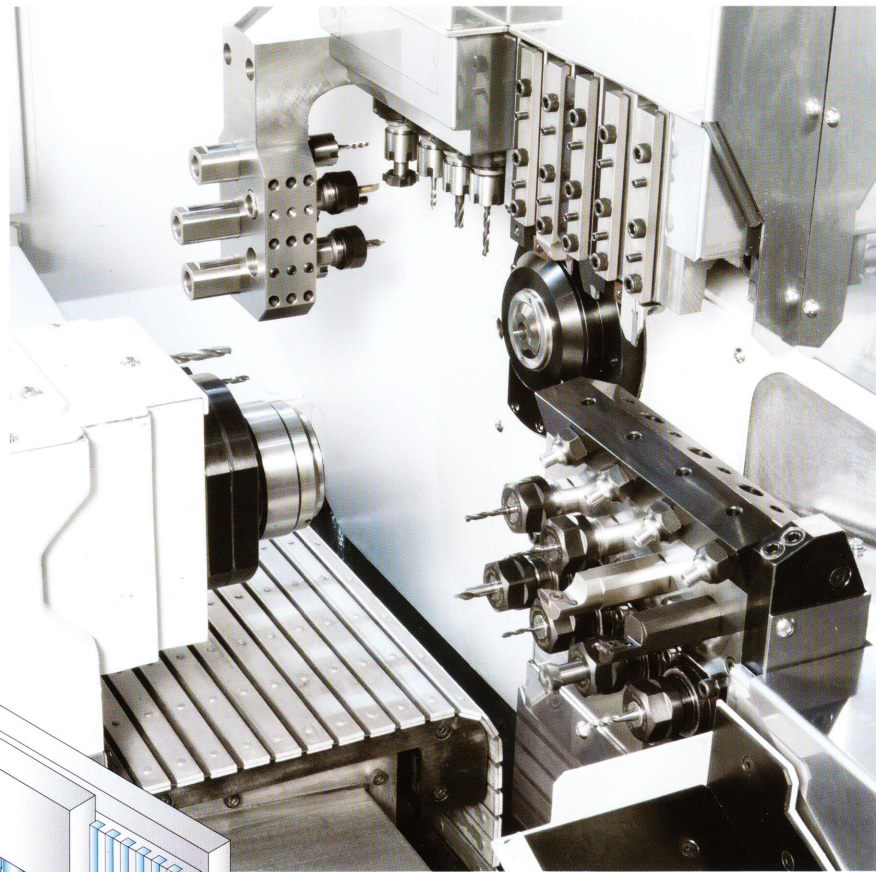

※ Applied for SA20P

High Rigidity

- Body Structure Design by FEM Analysis Program
- Tool Stand with Low Center of Gravity Design
- One Piece Casting Bed Type with LM Guide links to Bed
- Outstanding Machining Capability with Powerful Motor and LM Guide
- Synchronous Rotary Guide Bushing Holder
- Power Chucking Toggle System
- ER16 Collet for Revolving Tool
- Rapid Traverse Speed : 32M/min.

Guide Bushing System

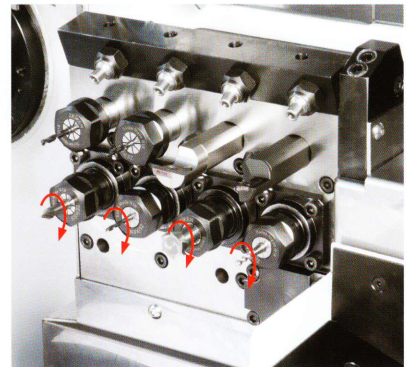
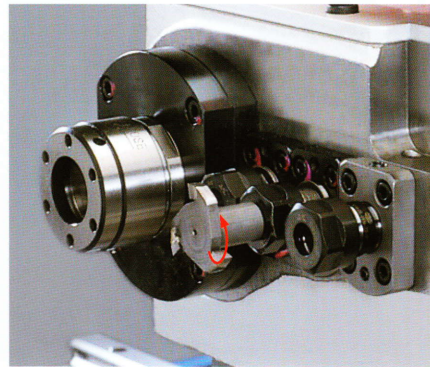

Easy Operation System

- Easy Positioning Operation Panel with the Convenience and MPG Mounted
- Fully Opening Type Covers & Doors (RH / LH)
- Minimized Operational Key with Software Configuration
- Easy for Trouble Check and Remedy by Modulated Pneumatic System
- Slant Bed Structure with Easy Chip Disposal / Coolant Discharge

High Accuracy

- Ultra Precision Ball Screw / LM Guide
- 1/1,000° Positioning, Cs for Main & Sub Spindles
- Pneumatic Brake with High Accuracy / High Rigidity for Main & Sub Spindles
- Keep Optimal Repeated Precision Level by Ball Screw Dual Pressure

Convenience

- Coolant Ejection from Each Tool Block
- Easy Chip Disposal with Downward Tool Direction
- Safe & Versatile Shock Protection Software
- Easy & Simple Operational Panel
- Versatile Tool Management Program

Reliability

- Outstanding Electric System using all Fanuc Products
- Cut-Off Tool Breakage Detector by Mechanical Sensors
- Complete Oil Block for Main Spindle Area by Dual Slide Cover
- Cable, Sensor, Main Spindle, Ball Screw Protected against Erosion or Hardening
- Regular CNC Educational Program Course Available

Polygon Attachment (Optional)

- Cost Effective Device with High Speed
- Heavy-Duty Cutting : 1.5 kW / 2.2 kW (Fanuc)
- Programmable Polygon Angle Available
- Easy Tool Set-Up

Rotary Guide Bushing Unit

- Rotary Synchronous Type
- Dual Bearing Structure with High Accuracy
- Strong and Accurate Bearing Support on Both Ends
- Spline Shaft Driven

Powerful Back-End Tool Station

- Balanced Process by Powerful Back-End Machining Reducing Cycle Time
- Rigid Off-center Drilling and Tapping with High Speed and High Accuracy
- No. of Tools : Std. 4 (Live 2, Fixed 2)
Opt. 8 (Live 4, Fixed 4)
- Max. Spindle Speed : 5,000 rpm
- Motor Output : 1.0 kW (Fanuc)

Rigid Tapping Function

- Tap Holder not Required
- Save time with High Tapping Speed

Modular Type Drilling Unit (Optional)

- Simple Change for Driven Tools / Fixed Tools (Back Tools)
- Special Tool Holder Adoptable (Cross)
- Angled drilling, Whirling, Hobbing, Slotting Unit

LAY-OUT

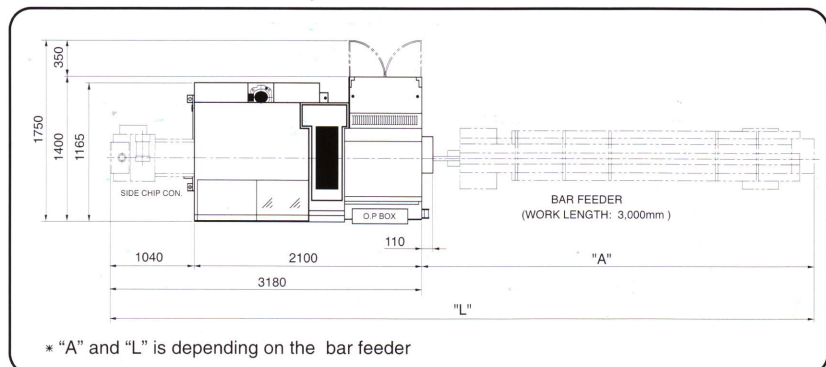

Machine Specification

Part	Description	SA20P	SA26P	SA32P	SA38P
Machining Capacity	Max. Turning Bar Dia.	∅20mm	∅26mm	∅32mm	∅38mm
	Max. Turning Bar Length	210mm (N:60mm)	210mm (N:60mm)	210mm (N:80mm)	210mm (N:80mm)
	Max. Main Spindle Drilling / Tapping	∅10mm / M8	∅12mm / M10	∅12mm / M10	∅12mm / M10
	Max. Sub Spindle Chucking Dia.	∅20mm	∅26mm	∅32mm	∅38mm
	Max. Back-end Face Drilling / Tapping	∅8mm / M6	∅10mm / M8	∅10mm / M8	∅10mm / M8
	Max. Cross Drilling / Tapping	∅8mm / M6	∅10mm / M8	∅10mm / M8	∅10mm / M8
	Max. Cross Disc-Mill Dia.	∅32mm	∅40mm	∅40mm	∅40mm
Capability	Max. Main Spindle Speed	8,000rpm	8,000rpm	8,000rpm	8,000rpm
	Max. Sub Spindle Speed	8,000rpm	8,000rpm	8,000rpm	8,000rpm
	Max. Cross Spindle Speed	6,000rpm	6,000rpm	6,000rpm	6,000rpm
	Total No. of Tools	26	25	25	24
	OD / Cross Live Tool / Y-Axis ID	6 / 4 / 5	5 / 4 / 5	5 / 4 / 5	5 / 4 / 5
	Front-end Face Tools (Sub)	3 (Live 2, Fixed 1)	3 (Live 2, Fixed 1)	3 (Live 2, Fixed 1)	2 (Live 2)
	Back-end Face Tools	Std 4 (Live 2, Fixed 2) Opt 8 (Live 4, Fixed 4)	Std 4 (Live 2, Fixed 2) Opt 8 (Live 4, Fixed 4)	Std 4 (Live 2, Fixed 2) Opt 8 (Live 4, Fixed 4)	Std 4 (Live 2, Fixed 2) Opt 8 (Live 4, Fixed 4)
	Bite Shank	□12×120mm	□16×120mm	□16×120mm	□16×120mm
	Rapid Traverse	32m / min.	32m / min.	32m / min.	32m / min.
	Controllable Axes	8	8	8	8
	Main Spindle Positioning	Cs + 1/1,000°	Cs + 1/1,000°	Cs + 1/1,000°	Cs + 1/1,000°
Sub Spindle Positioning	Cs + 1/1,000°	Cs + 1/1,000°	Cs + 1/1,000°	Cs + 1/1,000°	
Motor	Main Spindle	2.2 / 3.7kW	5.5 / 7.5kW	5.5 / 7.5kW	5.5 / 7.5kW
	Sub Spindle	1.5 / 2.2kW	1.5 / 2.2kW	1.5 / 2.2kW	1.5 / 2.2kW
	Cross Drill / Mill Unit	1.0kW	1.0kW	1.0kW	1.0kW
	Back-end Face Tools	1.0kW	1.0kW	1.0kW	1.0kW
	Coolant Pump Unit	0.9kW	0.9kW	0.9kW	0.9kW
	Lubrication Pump Unit	0.04kW	0.04kW	0.04kW	0.04kW
	Coolant Capacity	240ℓ	240ℓ	240ℓ	240ℓ
Dimension	Center Height	1,000mm	1,000mm	1,000mm	1,000mm
	Length×Width×Height	2,100×1,165×1,658mm	2,100×1,165×1,658mm	2,100×1,165×1,658mm	2,100×1,165×1,658mm
	Net Weight	3,200kg	3,400kg	3,500kg	3,500kg

* Above specification may be changed without prior notice.

NC Specification

Description	SA20P / 26P / 32P / 38P
NC Controller	FANUC 31i-A
No. of Controllable Axis	8
Axis Designation	Z1, X1, Y1, Z2, X2, C1, C2, Y2
Min. Input Increment	0.001mm
Min. Command Increment	0.001mm (X axis : 0.0005mm)
Max. Programmable Value	±8 digits
Interpolation Function	Linear / Circular
Rapid Traverse	32m / min.
Feedrate	1~6,000mm / min.
Feedrate Override	0~150%, 10% Step
Dwell	GO4 0.0001~9999.999
ABS / INC Command	X, Y, Z, C : Absolute U, W, V, H : Incremental
Tool Offset	±6 digits
No. of Tool Offset	64 sets
CRT / MDI	10.4" COLOR LCD
Display Language	English, Others
Tape Memory	512 Kbyte (1280m)
No. of Registerable Program	500 sets
Miscellaneous Function	M5 / M3 digits
Main Spindle Function	S4 digits
Tool Function	T4 digits

* Above specification may be changed without prior notice.

Machine Standard

Synchronous Rotary Guide Bush Holder Unit
Part conveyor
M-code Air Blow
Part Ejection Detector
Front-end Face Revolving (2)
4 Spindle Cross Drill Unit
Main / Sub Spindle Positioning : 1/1,000°
Cs Control on Main & Sub Spindle
Back-end Face Tool Unit (Live 2, Fixed 2)
Coolant Flow Detector
Tool Height Gauge
Work Light
Patrol Light
Barfeeder Interface
Service Tool Kit
Instruction Manual
FANUC Manual (Operator / Maintenance / Parameter)

Machine Option

Barfeeder
Long Part Discharging Unit
Chip Conveyor
Back-end Face Tool Unit (Live 4, Fixed 4)
Sub Spindle Pneumatic Brake Unit
M-code Oil Blow
Front-end Face Revolving Unit (3~4)
Cut-Off Breakage Detector
Fixed Type Guide Bush Holder Unit
Polygon Attachment
Y-Axis Tool Unit
Thread Whirling Device

NC Standard

Circle, Semi-circle Designation
Override Cancel
Work Coordinate Shift (G50)
Machine Lock
Single Block
Self-Diagnostic Function
Software Operation Panel
Tool Offset Display
Input / Output Interface
Working Hour / No. of Part Display
Tool Radius Compensation
Chamfer / Corner R
Automatic Power-Off
Inch / Metric Conversion
Back-ground Editing
Constant Surface Speed Control
Chasing Function
Synchronous / Composite Function
Z1-Z2 Synchronous Function
MPG(handle wheel) : 0.001mm
Synchronous Control (Main & Sub)
Rigid Tapping on All Spindles

NC Option

MPG Program Check
IC Card
Additional G-Code
Remote Control System (Ethernet)
Fanuc Warranty Service (2 years)

NEXTURN
SWISS TURN LEADER

- 400-29, Gomae-Dong, Kiheung-Gu, Yongin-Si, Kyungki-Do, Korea
TEL:82-31-288-2092
FAX:82-31-288-2094
- E-mail : overseas@nexturn.co.kr
- Homepage : http://www.nexturn.co.kr



ISO 9001 / 14001 Registered Firm

Printing date : 15/ 4/ 2012